

IBM Research AI

Intelligent Assets & Operations

Early Access Offering

IBM Research

Overview of Intelligent Assets and Operations

Intelligent Assets and Operations (IAOps)

Assets and critical infrastructure

They require greater operational efficiency with reduced manual intervention.



Signals from operations communicate information

AI can help to decode the signals and improve operations



From sensor and event data to greater operational insight

Improve responsiveness, reliability and operations costs by identifying anomalous behaviors, predicting failures, provide advanced warnings and identify root causes.

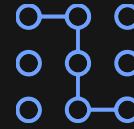

Scope

from sensor & event data

- Anomaly detection
- Failure pattern analysis (FPA)
- Cohort analysis for fleet data
- Root cause analysis
- Modeling dynamic systems
- Behavior dictionaries from data
- Privacy preserving anomaly detection & FPA

Unique Proposition

- Full AI pipeline customized for industry automation
- Large suite of novel and specially adapted algorithms for insights into plant behavior
- Complete, purpose-built stack validated with clients

Intelligent Assets and Operations

Toolkits for analyzing and extracting asset and plant behavior from temporal data

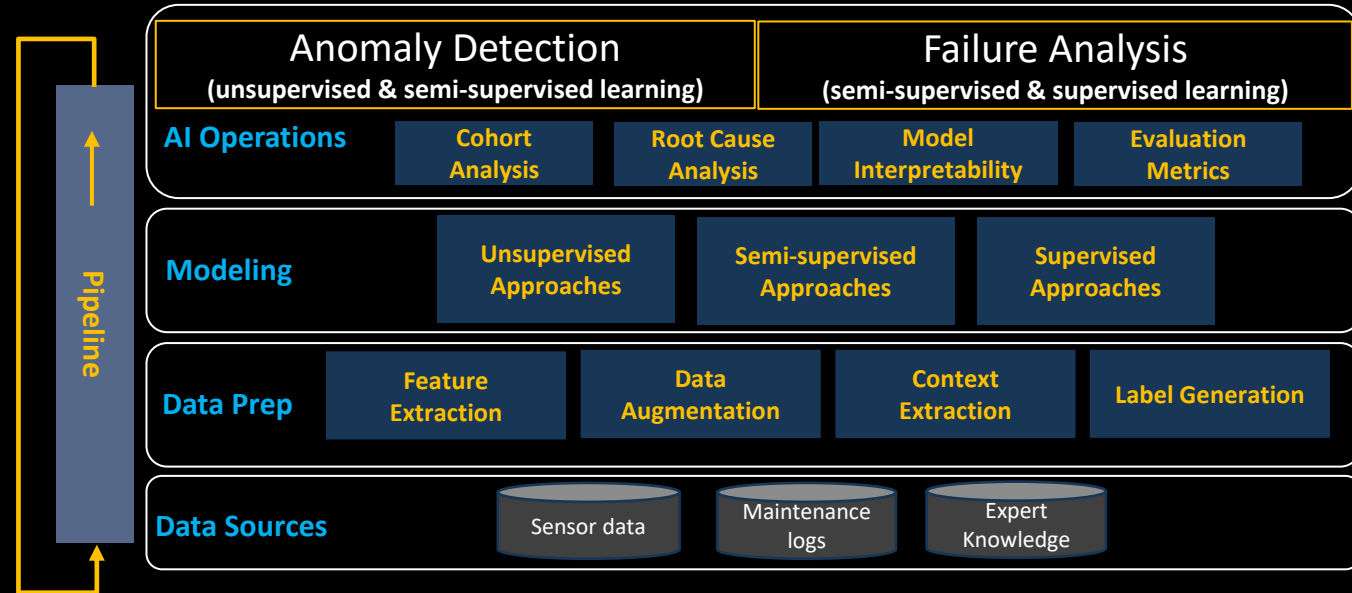

Key differentiating areas:

- **Many Algorithms** – novel and specially adapted algorithms uniquely packaged for domain
- **Asset Centric Analysis** – mode discovery, asset grouping using cohort analysis, test/train split based on assets
- **Class Imbalance Discovery and Modeling** - support for multiple imbalanced pipelines including weight balancing, ensemble balancing, boosting balancing approaches
- **Contextual understanding** – semantics aware feature engineering, root cause analysis

Modeling dynamic systems with time series

Prepare



Manipulate



Transform



Model



Refine



Model Pipeline

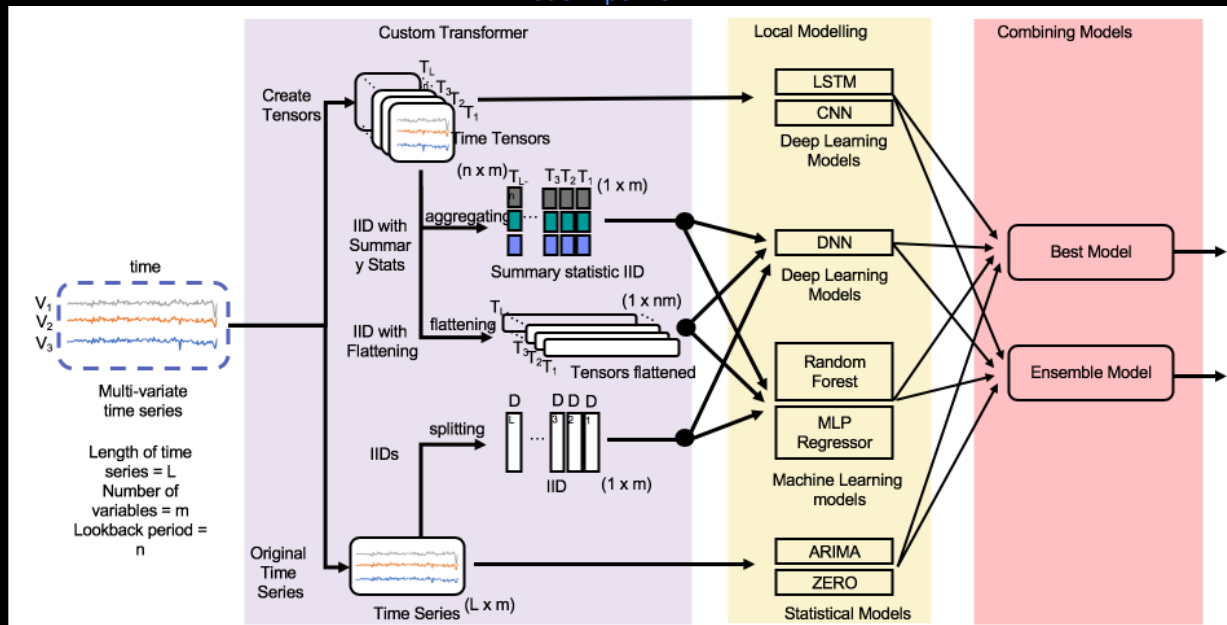

Construct model pipelines from your IoT data

Time Series models from sensor data can be used to forecast future behavior.

Models emerge from constructed pipelines that enable

- data transformation,
- feature engineering,
- parameter optimization,
- model selection,
- model ensembles

Full suite of modeling approaches: from standard statistical algorithms, to machine and deep models, to hybrid statistical neural methods

Anomaly and failure analysis approaches depend on data availability

Provides state of the art approaches and algorithms for a variety of typical situations

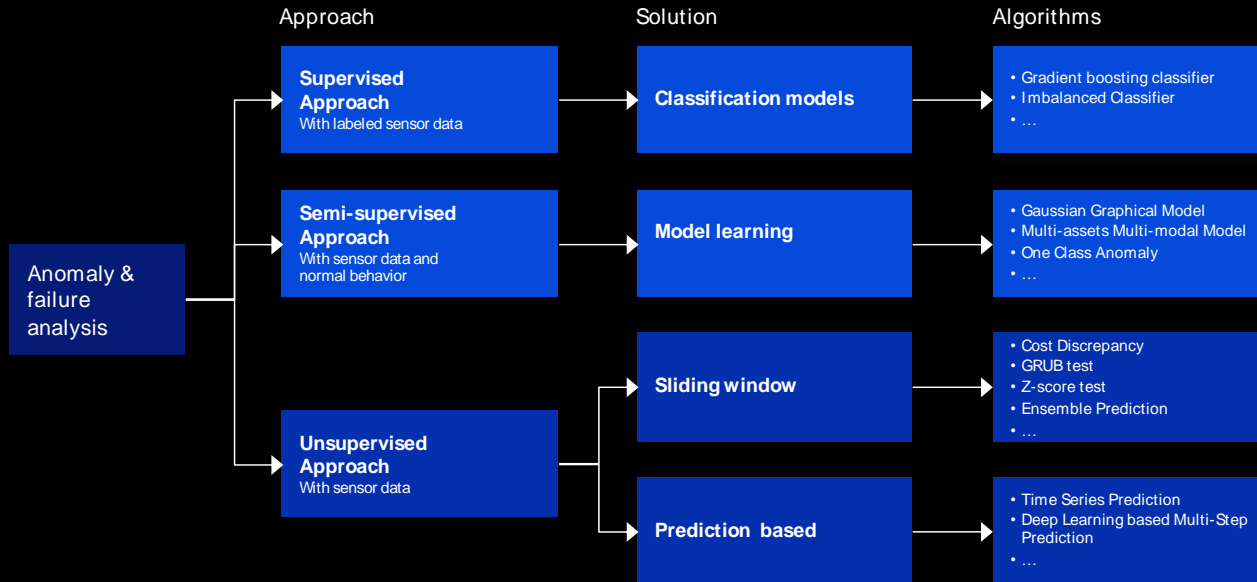

Construct model pipelines to create models that detect and classify anomalies and failures

How anomaly and failure prediction is done is determined by the amounts and types of data that are available

The package includes tools for

- Supervised learning
- Semi-supervised learning
- Unsupervised learning

AI-based process failure prediction

Used to develop a classifier model to predict impending machine failure using a supervised learning approach over labelled sensor data

Objective

Predict imminent failures by analyzing the time-series data from sensors

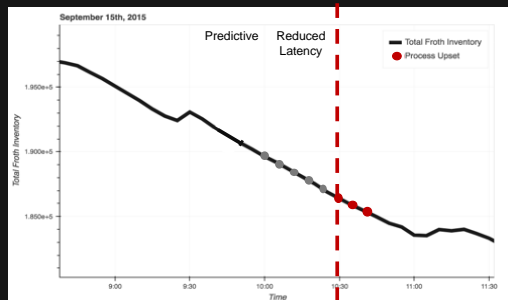

Rule-based
upset flag

Approach

Convert sequence of IoT sensor data and labeled failures to a classification problem to predict imminent failures within a given future window

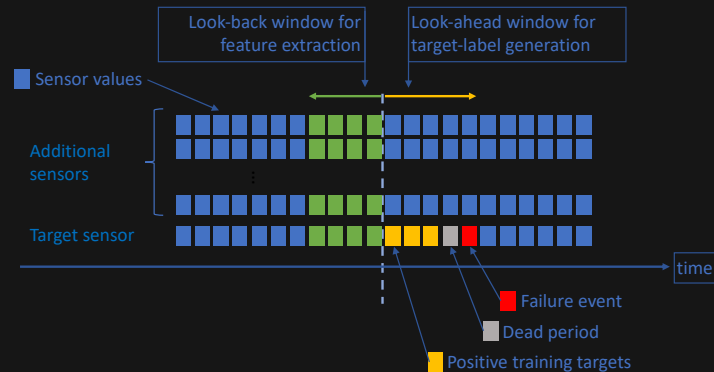

Semi-supervised anomaly detection

Time series information from sensors leads to an ordering among the sensors, reflecting dependency (represented as linked graphs). Dependency patterns change under anomalous conditions. Scoring the difference between dependency graphs can be used as an indicator for anomalous behavior.

Training

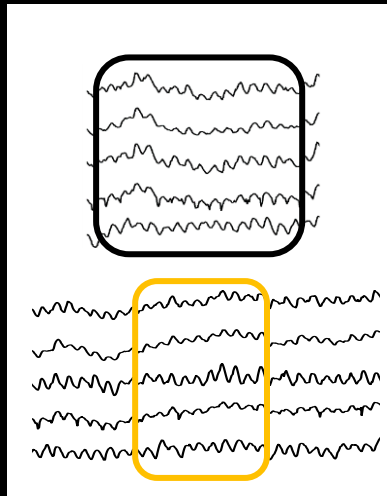

Machine Learning

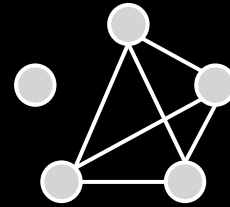

Compute dependency graph in the training region

Do the same for the test region

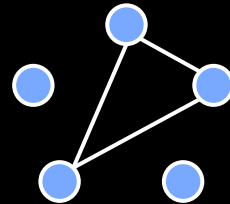

Compare and compute change score and provide alerts

Fully automated and no manual feature engineering required

Cohort analysis for asset fleets

- A small collection of models capture principle behaviors
- Each asset is expressed as weighted contributions of principle behaviors
- The sparsely expressed weights can be used to characterize assets into similarity groups

In many settings, there are cohorts of assets for which predictive models are needed

Straightforward solutions have serious limitations

One model per asset
Many models to manage and training suffers from a lack of fault examples.

Universal model
Model fit is not good and disregards individual conditions.

Sparse Mixture Models

Captures both individuality and commonality

Robust to noise

Highly interpretable for diagnosis purposes

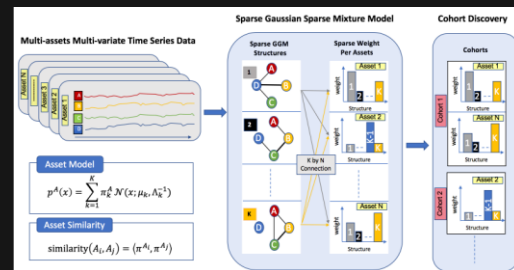

Behavior dictionaries from data

- This capability projects signal segments (windows) into a compressed representation (embedding) generated by a neural autoencoder that identifies a set of behavior modes.
- Signal segments can be clustered into these behavior modes, the totality of which represents the operating universe.
- The current operating mode can be understood in relation to its neighborhood and analyzed for required changes to adjust the mode.

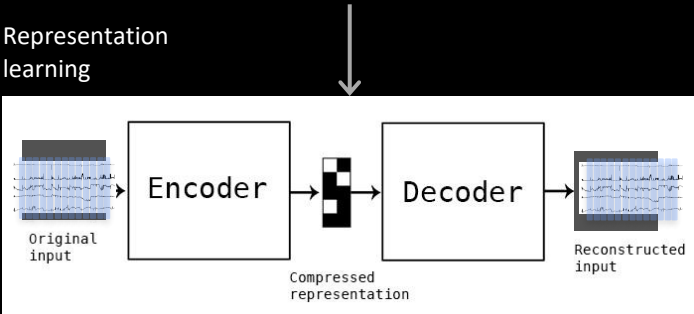
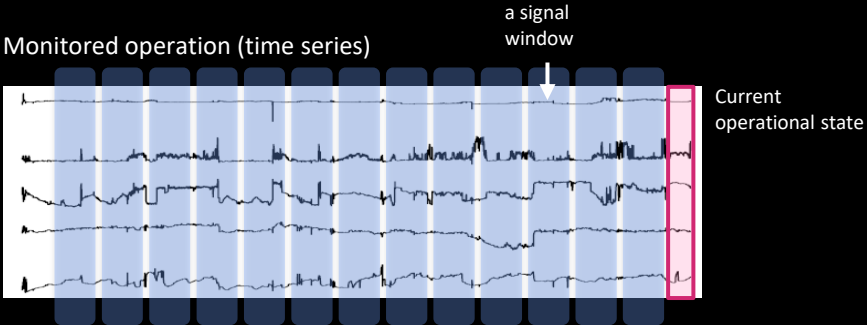

Mode based performance characterization

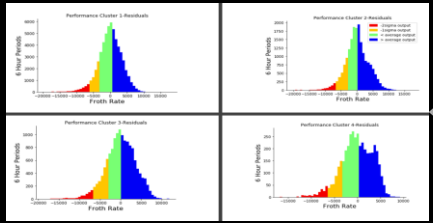

Behavior mode discovery

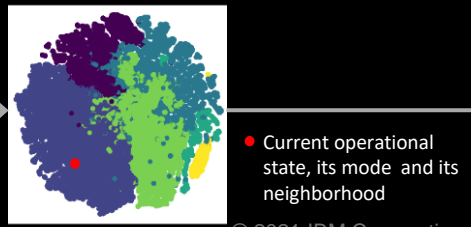

Privacy preserving anomaly detection and failure prediction

State of the art homomorphic encryption machine learning to protect data and model confidentiality

In some cases, data or trained models are sensitive and confidentiality needs to be protected

Provides privacy-preserving anomaly detection and failure prediction analysis leveraging encrypted computations and machine learning

Supports homomorphically encrypted machine learning for supervised and unsupervised machine learning models

Machine Learning with Homomorphic Encryption

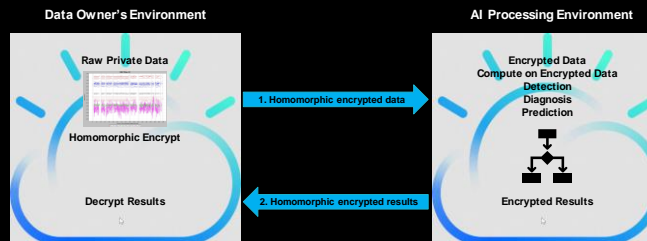

Privacy-preserving Asset Anomaly Detection
Unsupervised AD for on HE encrypted data

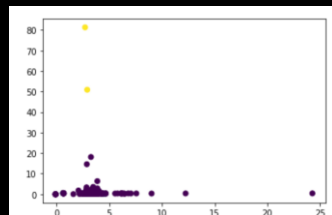

Privacy-preserving Asset Failure Prediction
Supervised Failure Prediction with structured data

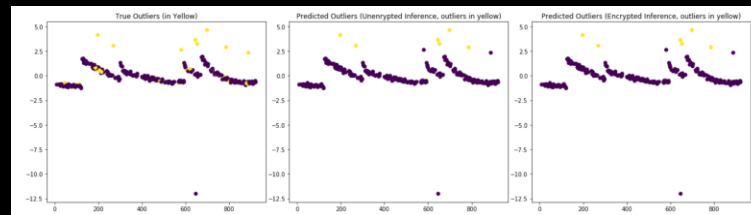

Uses and Benefits of Intelligent Assets and Operations

Industry Challenge: Efficiently and Effectively Optimize Anomaly Detection and Predictive Model Performance

Objective

1. Identify best analytical pipeline components and best parameters for models
2. Optimize analyst and engineering model development time and effort

Complications

1. Design of an analytical pipeline may include considerations of hundreds of options for feature engineering, feature selection, model algorithm, train and test protocols, etc.
2. Optimization of any given analytical pipeline may include search over a vast number of parameter combinations in a multimillion-dimensional search space

Current Practice & Shortcomings

1. Traditional expert model development methods may consider only known best components: Best known components may underperform components selected via a comprehensive search of possible components
2. Traditional semi-automated methods for parameter and hyper-parameter optimization may conduct only a limited un-intelligent search: Optimally performing parameters are not discovered
3. Semi-automated development and testing of different potential pipelines: Requires extensive data scientist and engineering development time and effort

Multiple Options to be Considered for Each Stage of Pipeline

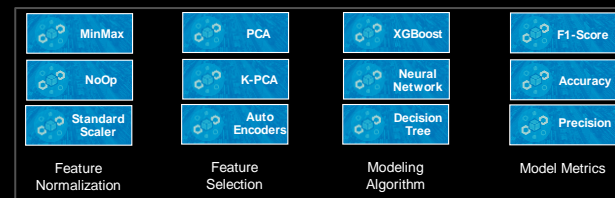

Large number of Parameters to Be Evaluated For Each Possible Component

Industry Challenge: Product & Process Anomaly Detection & Root Cause Diagnosis in Non-Stationary Systems

Objective

1. Enable proactive detection of anomalies in non-stationary systems
2. Enable root cause diagnosis in non-stationary systems

Complications

1. Chambers', subsystems', and components' behaviors change over time, reflecting discrete (maintenance) events and normal evolution over time
2. Normal data to be monitored or investigated as potential root cause contributor shows non-stationary behavior
3. Difficult to develop models that will robustly detect anomalous events over time

Current Practice & Shortcomings

1. Anomaly detection thresholds may recognize all plausible values as normal, ignoring temporal context: Detection sensitivity is dramatically reduced
2. Models may be updated frequently to account for non-stationarity: Excessive engineering time and effort expense

Normal Time Series Data Shows Non-stationary Behaviors

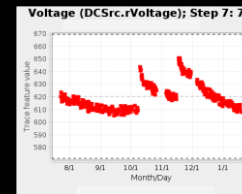

Event to be Detected

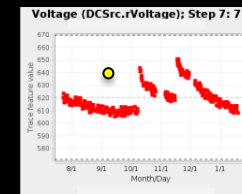

Low Sensitivity Detection

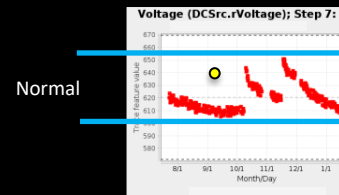

IAOps Enabled Solution: Product & Process Anomaly Detection & Root Cause Diagnosis in Non-Stationary Systems

Developed method to exploit sparse mixtures of sparse graphical gaussian models (GMM) for anomaly detection in non-stationary systems

1. Method widely used in other settings (e.g. fleet matching analytics), not obviously applicable to this difficult problem
2. Demonstrated effectiveness with univariate and (limited) multivariate data sets
3. Demonstrated effectiveness in forward looking use cases (e.g. FDC) and in backward looking use cases (product aberration diagnosis)

Developed multilayer GMM models with improved performance over single layer models

Challenge

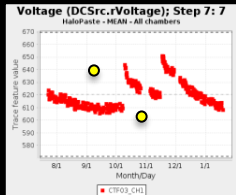

Sparse Graphical Model

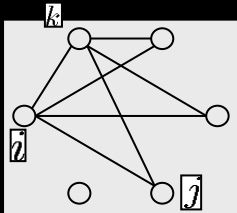

Anomaly Score Detects Outliers

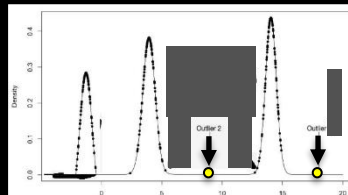

Anomalies More Distinct and Explainable With Two-layer Architecture

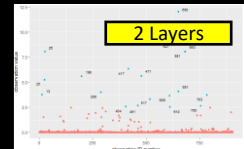
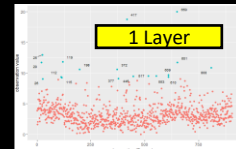
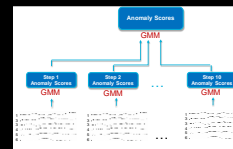

Industry Challenge: Optimize Analytics While Protecting IP

Environment

1. Fab data is not shared with OEM
2. Field data may not be shared with Fab
3. Limits product, process, tool learning & diagnostics

Objectives

1. Improve analytical models by incorporating sensitive / private / multiparty datasets in privacy preserving manner
2. Improve models development by effective multiparty analytical collaborations

Challenge

1. Data used for model development, data for analysis, and models themselves may incorporate IP which must not be shared

Current Practice & Shortcomings

1. Sharing of data and models is limited to minimize chances of IP leakage
2. Third party analytical results are limited in content
3. Potential insight from third party model development and structure is lost

Solution

1. Development of privacy preserving techniques for data analysis and machine learning

Field of View Limited for Image Analyses Development

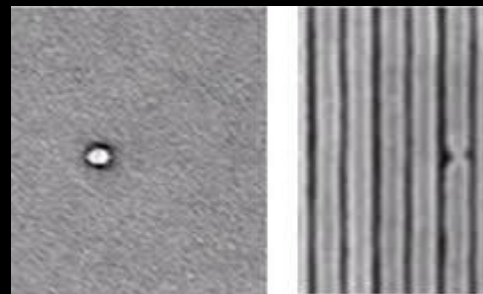

Incomplete Sharing of Process Trace Data & Analyses

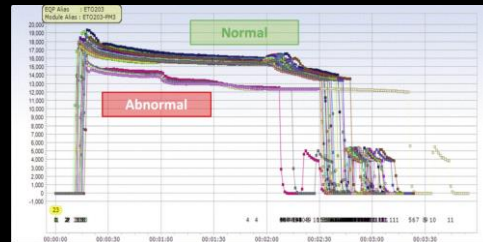

IAOps Privacy Preserving Analysis

Anomaly Detection (FDC, SPC, applications)

In time series of summary trace statistics
In vectors of on-wafer measurements

Detected Anomalies, Unencrypted Inference



Detected Anomalies, Encrypted Inference

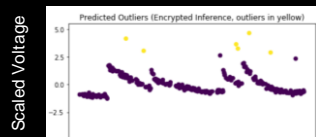

Predictive Models (VM, PredMaint applications)

Infer an effect given summary statistics of process trace data

Unencrypted Linear Inference

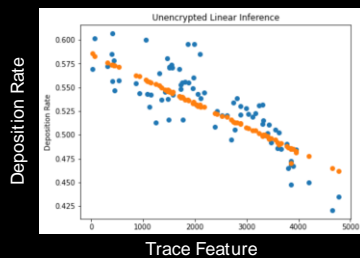

Encrypted Linear Inference

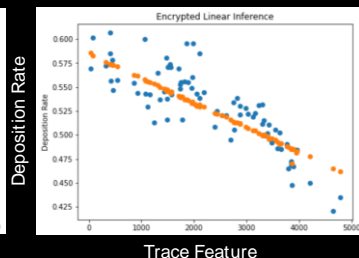
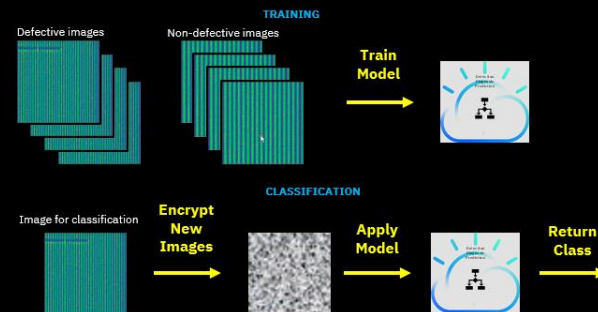

Image Analysis (Detection and Classification applications)

Defect free or defect containing image classification



Privacy-preserving Statistics and Benchmarking

Private computation of aggregations, statistics & benchmarks

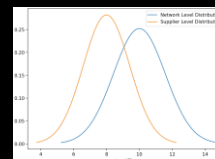

- Statistics (mean, std-dev of data), distance/similarity computation, matrix operations (such as multiplication, addition etc.), vector operations (dot product)
- Benchmarks: mean, std-dev, similarity (distance) computations and more advanced matrix & vector operations

IBM Research **Intelligent Assets and Operations** Early Access Offering

AI for Intelligent Assets and Operations Research Access

Framework, Duration, Investment:

- Licensed access to the assets for AI for Intelligent Assets and Operations (IAOps)
(early access to pre-product features)

Technology Access:

Access to IBM Research's Intelligent Assets and Operations:

- Access to research assets ranging from early experiments and algorithm design to pre-product software prototypes
- Includes code, internal papers, demo applications and example use cases
- Software updates as new features become available throughout the duration of the partnership
- Strong validation of approaches based on significant client experience
- Integrated package to get more asset management value from IoT sensors monitoring assets

Access Benefits

Training and Support:

- Onboarding and deep training half-day launch workshop
- Technical consultation for up to 15 hours/quarter
- Update and interlock workshop each quarter for potential use cases and technical update discussions

AI for Intelligent Assets and Operations Research Capabilities include:

- Anomaly detection for assets data
- Failure pattern analysis for assets data
- Cohort analysis for asset fleet data
- Root cause analysis for assets
- Modeling dynamic systems with time series and behavior dictionaries from data
- Privacy preserving anomaly detection and failure prediction

IBM Research AI Early Access Program

- Mature IBM Research Toolkits (with limited support) made available to clients to use within their enterprise
- Toolkits architected for immediate deployment
 - Includes a fixed amount of training and support (80+ hours)
- Client has access for a period of one year but is enabled to use the results for internal commercial benefit in perpetuity
- Early Access toolkits are well aligned in vision, target roadmap, and deployment with IBM's commercial business

The IBM Research AI Offerings Portfolio

AI for Industry

AI-based Situational Awareness

Achieve operational oversight of physical plants by developing and maintaining an active semantic representation of infrastructure and use intelligent query mechanisms on this data.

Intelligent Assets & Operations

Monitor, understand and predict machine behavior by symbolic modeling of behavior classes to detect early signatures of anomalies, and find the root cause of failures.

Intelligent Process & System Optimization: Data to Decisions

Optimize operations of physical assets by leveraging advanced optimization techniques to recommend maintenance plans and system-wide plant optimization schemes.

AI for Business

AI-driven Customer Care

Automate customer care operations, enhance agent experience, and extract valuable business insight from data by leveraging state of the art language models and other AI techniques.

Project Debater

Support decision-making by extracting pros, cons, and key points from massive corpora, surveys or crowd-sourced data by leveraging Project Debater's language understanding and narrative capabilities.

AI for Business Automation

Optimize the workforce using AI that can monitor and recommend automations and by embedding digital assistants that can work alongside humans via natural language interfaces.

AI Automation & Trust

AI Trust

Enhance the explainability and reduce bias of models for increased confidence and utility in AI models

AI Automation & Lifecycle

Reduce and simplify the labor involved in building and deploying AI applications, extend the types of data that can be modeled, and help manage models once produced and deployed.

Data Quality for AI

Improve the quality of data early in the AI development cycle by automating data quality analysis, remediating data deficiencies, and replenishing with sampled, synthesized or augmented data.

Two complementary offerings to Intelligent Assets and Operations

- AI Based Situational Awareness
- Intelligent System and Process Optimization

AI-based Situational Awareness



managers, operators,
SMEs, data stewards

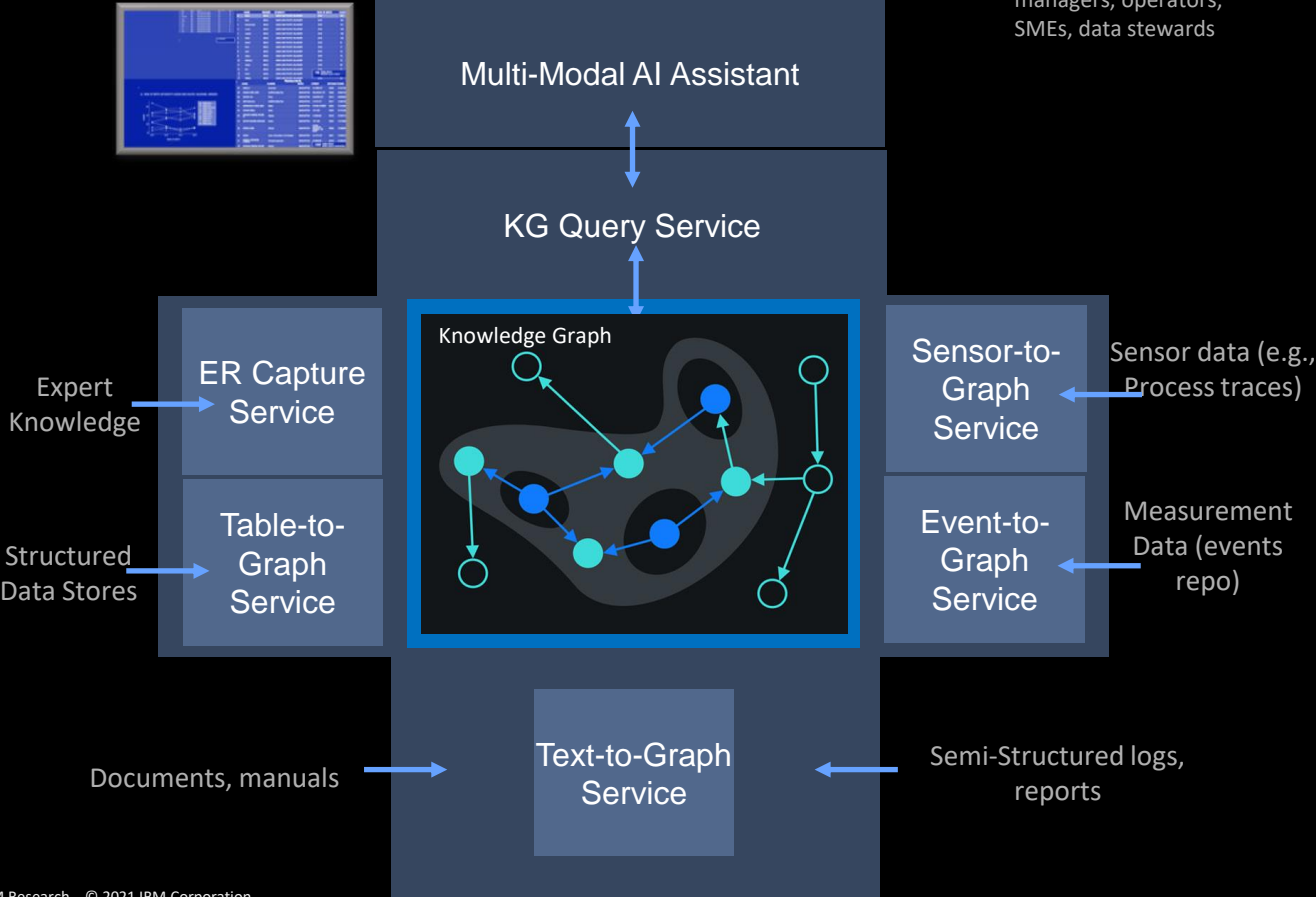

Scope

Achieve operational oversight of physical plants by developing and maintaining an active semantic representation of infrastructure and use intelligent query on this data.

Key Technologies

- Specialized capture services for knowledge sources, relational DBs, sensor data stores, event data stores, and informative text sources
- Query service for use with most KG technologies
- Unique cognitive UI reacts to voice and gesture

Value Proposition

- A spatial, temporal, and contextual representation of the state of a plant.
- Workflows: pre-defined and user-defined pipelines provide consistency
- Rapid access to contextualized information enables responsive and proactive operators
- An AI-enhanced interface possessing semantic awareness of the domain model. Integrates different interaction modes

Intelligent System & Process Optimization

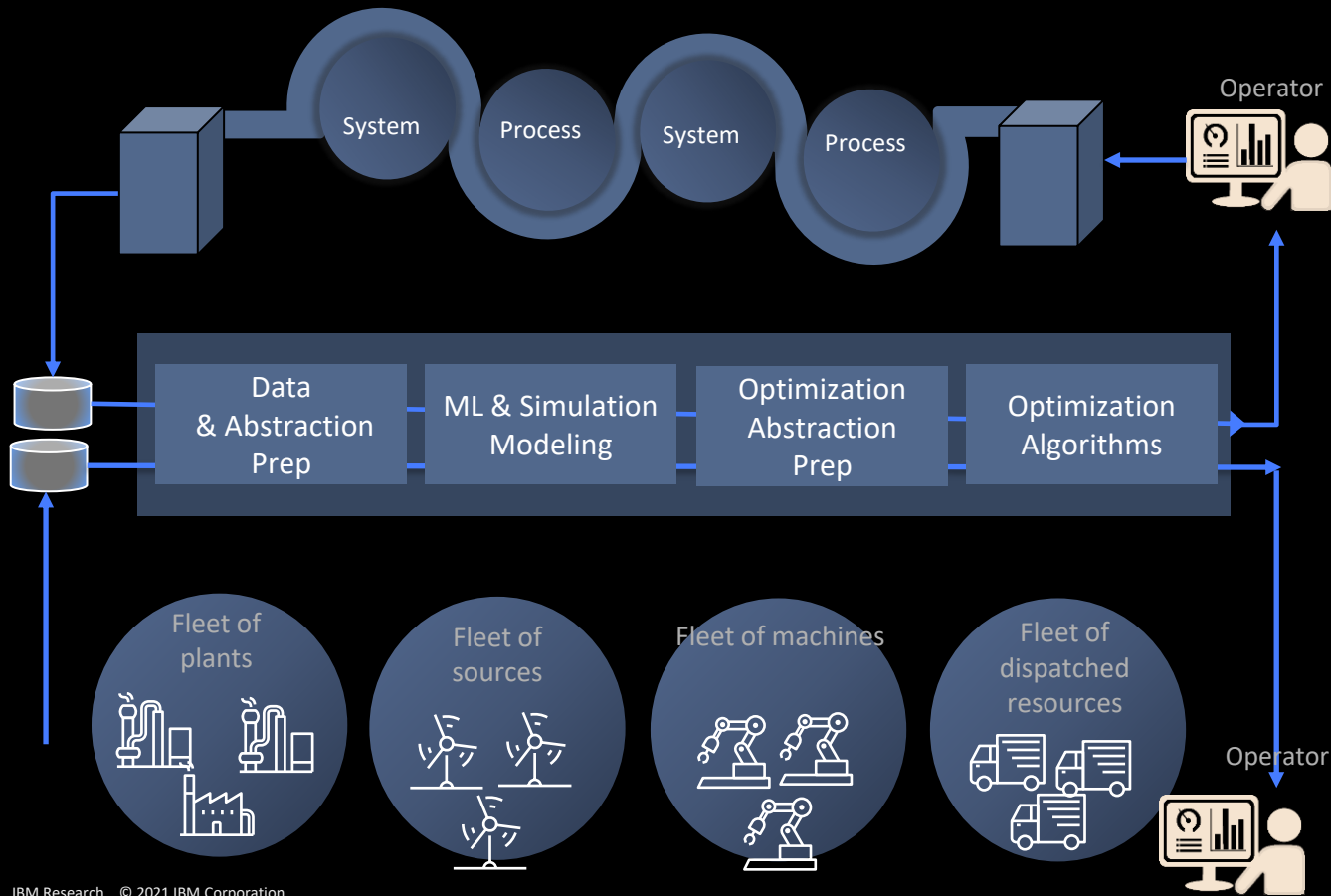

Problem Solved

Optimize operations of physical assets by leveraging advanced optimization techniques to recommend maintenance plans and system-wide plant optimization schemes.

Key Technologies

Physical Systems addressed:

- Functional Unit (U), System (S), Fleet (F)
- Regression-Optimization: behavior and optimal set points (U)
- Piecewise linear + MILP (S)
- DL + non-linear optimization (S)
- Ensemble models + Derivative Free Optimization (S)
- Assets and health optimization (F)

Value Proposition

- Multi-resolution** – appropriate for different hierarchical levels of control
- Industry agnostic** – applicable to any type of industrial processing using abstraction layers
- Industry ready** – specially adapted algorithms packaged for industry
- Real-time optimized adjustments** – real-time, data-driven adjustments to set points for responsive decisions

IBM's statements regarding its plans, directions, and intent are subject to change or withdrawal without notice at IBM's sole discretion.

Information regarding research is intended to outline our general direction and it should not be relied on in making a product purchasing decision.

The information mentioned regarding research is not a commitment, promise, or legal obligation to deliver any material, code or functionality.